

FTS9 QC Pipe Guide

Part #: DAQCPIPBK

| Parts List | | | |
|------------|-----|-------------|-----------------|
| ITEM | QTY | PART NUMBER | DESCRIPTION |
| 1 | 1 | 230016697 | Pipe Bracket |
| 2 | 2 | 600016683 | Wear Plate |
| 3 | 3 | MS380600B | Bolt 3/8 x 6.0 |
| 4 | 6 | S380WASHR | Washer Flat 3/8 |
| 5 | 3 | B38LOCNUT | Nut 3/8 Nyloc |
| 6 | 3 | MS380114B | Bolt 3/8 x 1.25 |

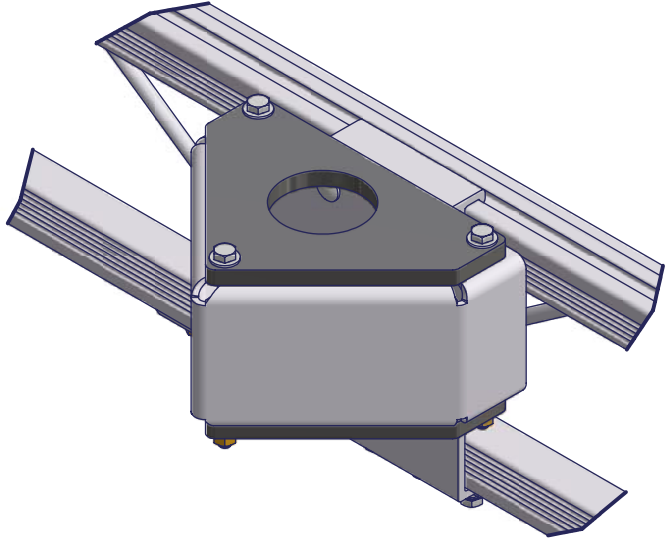
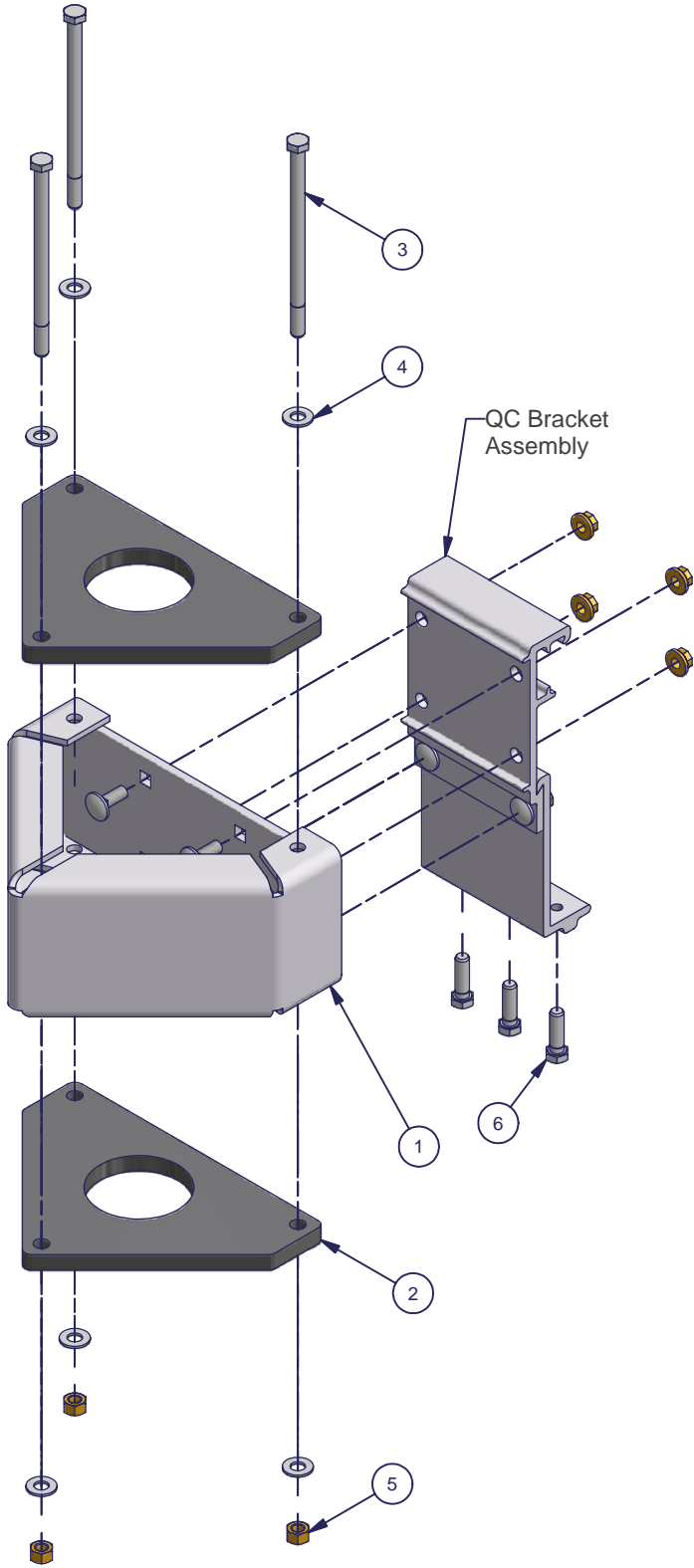

Assembly:

Assemble the QC Bracket Assembly and attach the Pipe Bracket as instructed in the TS9 Quick-Connect Accessory Connector Instructions.

Attach two Wear Plates to the Pipe Bracket. Secure with three Bolts 3/8 x 6.0, six Washers Flat 3/8 and three Nuts 3/8 Nyloc - as shown.

Attach the QC Pipe Bracket to the FTS9 Frame as instructed in the TS9 Quick-Connect Accessory Connector Instructions. Secure with three Bolts 3/8 x 1.25 - as shown.